

## Introducing our new Premier High Performance, Low Height, Energy Efficient Green Bottle Coolers



Premier low height bottle coolers come in single and double hinged glass or solid door models black or stainless steel. Offering all the features of our EcoChill models but with extra options included as standard. Designed to be fully built in under a bar without compromising the amount of bottles that can be displayed.



Advanced compressor and thermostat technology optimises compressor start and run conditions, and extends compressor life helping to cut your energy costs

Highly efficient evaporator and condenser fan motors

Enhanced thermal insulation complete with improved energy efficient sealed glass doors.

Low running and service costs with exceptional reliability & outstanding performance from one of the leading UK bottle cooler manufacturers in the UK today!

Designed for every type of catering and hospitality venue from restaurants to pubs, bars, cafes and stadiums, in fact anywhere that's needs to display cold beverages.

### FEATURES:

- / Choice of Black or stainless steel exterior
- / Brushed Stainless Steel D handle
- / Stainless steel Interior
- / Fully adjustable chrome shelves
- / Fully energy efficient illuminated (LED) maximised display area
- / Locks fitted as standard
- / Glass/Solid Doors
- / Displays 3 layers of premium beers
- / Forced air cooling for fast pull down times
- / Front breathing enabling cabinets to be fully built in
- / Rollers to the rear
- / Automatic defrost
- / R600a
- / Single door w600mm /Double doors w900mm
- / Made In The UK

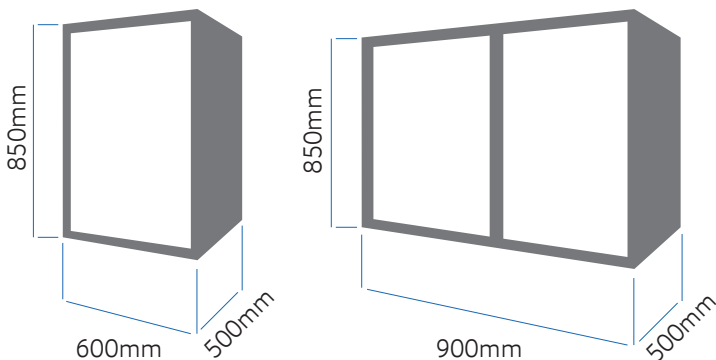



ENERGY SAVING

## Premier Low Height Energy Efficient Green Bottle Coolers

### Single Hinged Doors



**TAC05001**  
Single hinged glass door, black exterior, stainless steel interior, chrome shelves, LED lighting and lock.

**TAC05002**  
Single hinged glass door, black exterior, s/s door frame, stainless steel interior, chrome shelves, LED lighting and lock



**TAC05003**  
Single hinged glass door, stainless steel exterior/interior, chrome shelves, LED lighting and lock



**TAC05004**  
Single hinged black solid door, black exterior, stainless steel interior, chrome shelves, LED lighting and lock



**TAC05005**  
Single hinged s/steel solid door, black exterior, stainless steel interior, chrome shelves, LED lighting and lock



**TAC05006**  
Single hinged stainless steel solid door and exterior, chrome shelves, LED lighting and lock



### Double Hinged Doors



**TBC05001**  
Double hinged glass door, black exterior, stainless steel interior, chrome shelves, LED lighting and lock

**TBC05002**  
Double hinged glass door, black exterior s/s door frame, stainless steel interior, chrome shelves, LED lighting and lock



**TBC05003**  
Double hinged glass door, stainless steel exterior/interior, chrome shelves, LED lighting and lock



**TBC05004**  
Double hinged black solid door, black exterior, stainless steel interior, chrome shelves, LED lighting and lock



**TBC05005**  
Double hinged s/steel solid door, black exterior, stainless steel interior, chrome shelves, LED lighting and lock



**TBC05006**  
Double hinged stainless steel solid door and exterior, chrome shelves, LED lighting and lock



Model	Single Door	Double Door
Dimensions (mm) W x D x H	600 x 500 x 850	900 x 500 x 850
Bottle Capacities 330ml	96	130
Temperature Range	+3°C to +11°C	+3°C to +11°C
Shelves (Adjustable)	2	4
Refrigerant	R600A	R600A
Power Supply	13 Amp	13 Amp

### Options available



S/Steel Bar Handle



Colour Change LED

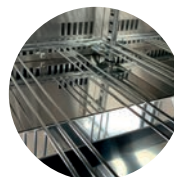

Wine Shelves

